

WELDING STANDARDS

Heavy Duty Steel Grating

The welding standards shown here apply to those gratings and treads having a clear opening of not less than 5/8" between bearing bars and those galvanized as per ASTM A-123.

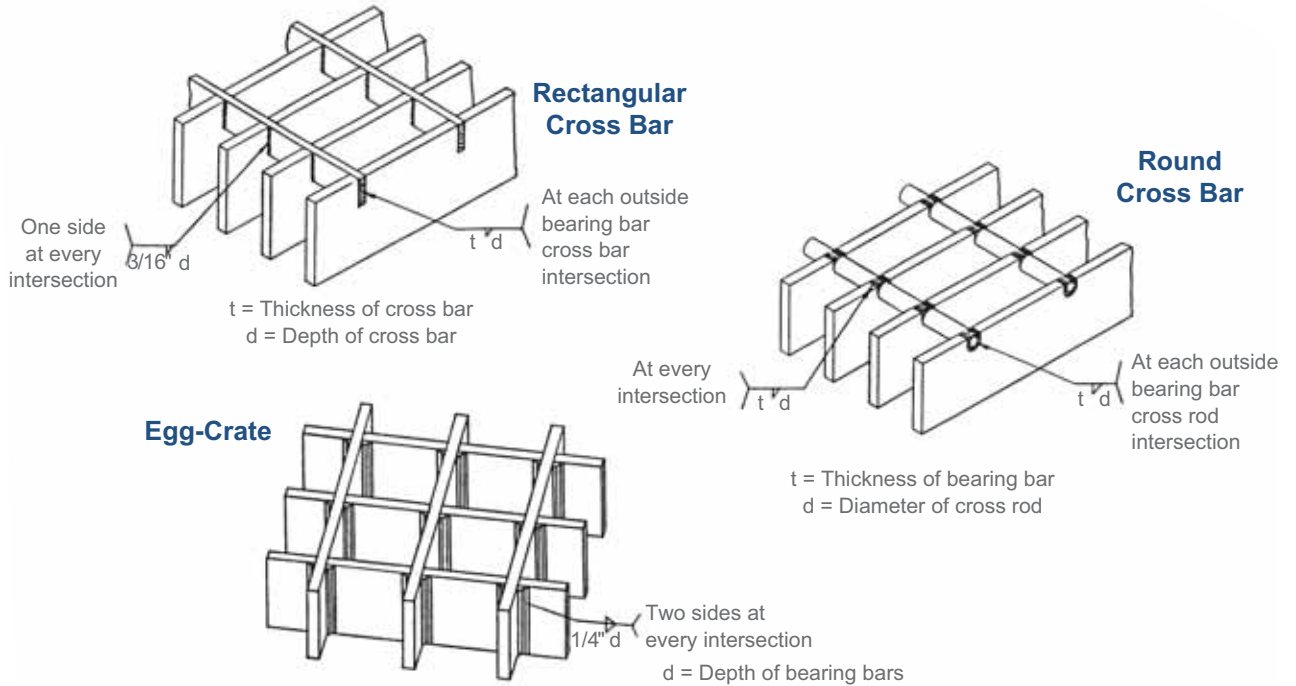

Toe Plates

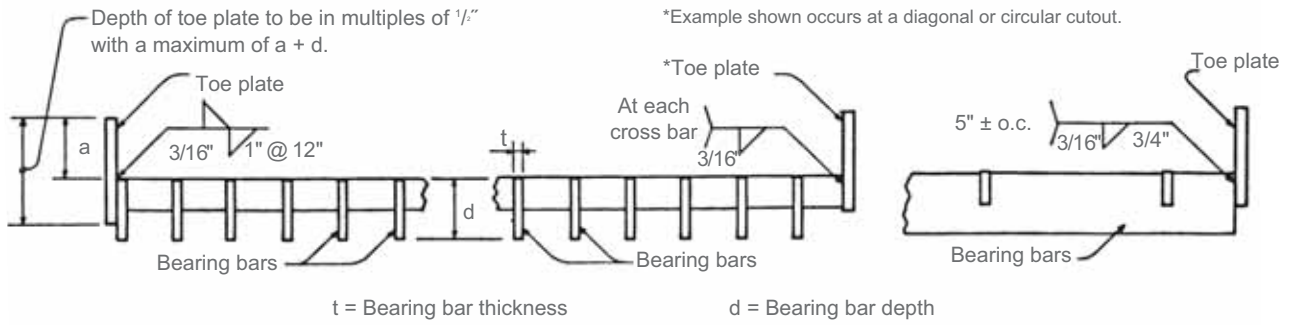

Banding

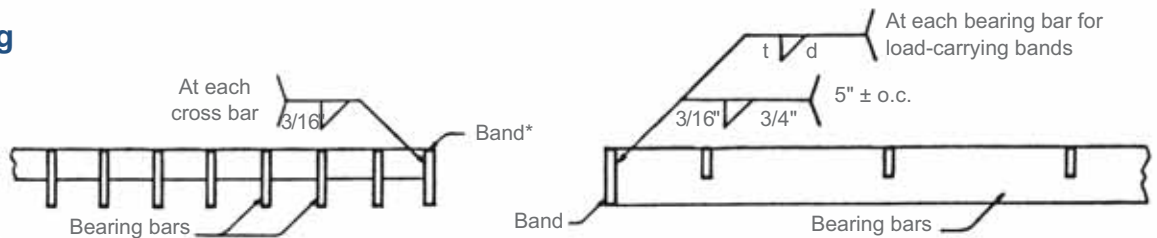

For depth less than 2-1/2" weld one side at top. For depth 2-1/2" or greater, weld one side at top, opposite side at bottom; or weld exceeding one-half depth on one side only. Minimum thickness = 1/4" For standard banding, band bar is same depth as bearing bars.