

WELDING STANDARDS

Light Duty Steel Grating & Aluminum Grating

The welding standards shown here apply to those gratings and treads having a clear opening of not less than 5/8" between bearing bars and those galvanized as per ASTM A-123.

Toe Plates

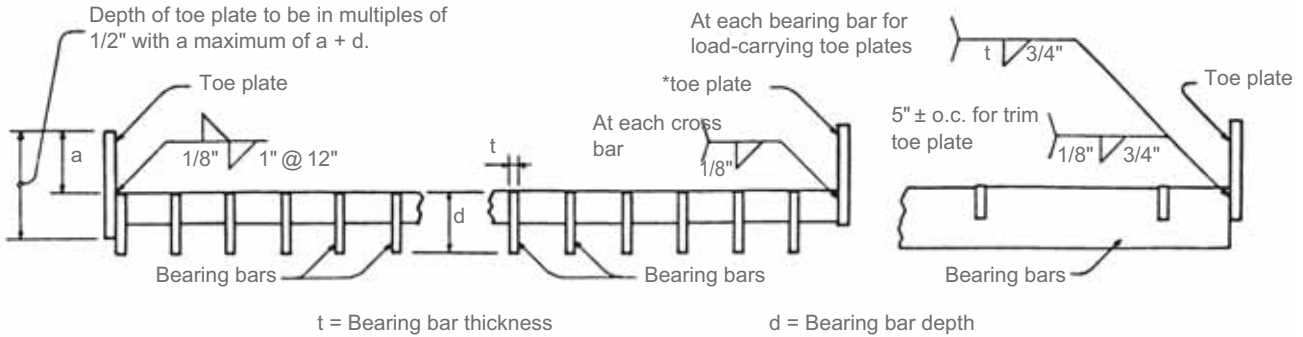

*Example shown occurs at a diagonal or circular cutout.

Banding

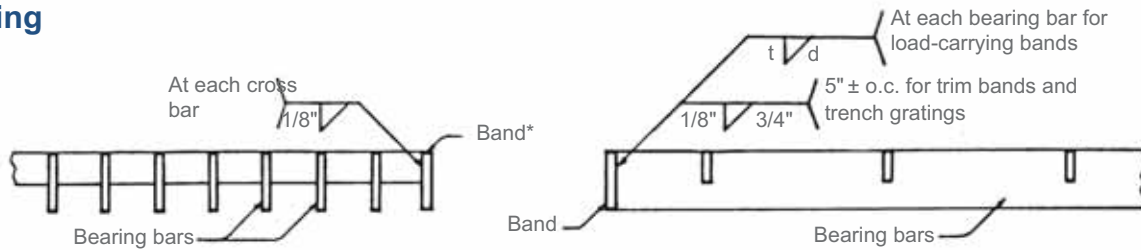

*Example shown occurs at a diagonal or circular cutout. Since the outside bearing bar becomes the edge bar of a panel width, side bands are never specified. Full depth banding will be provided unless otherwise specified.

Stair Treads

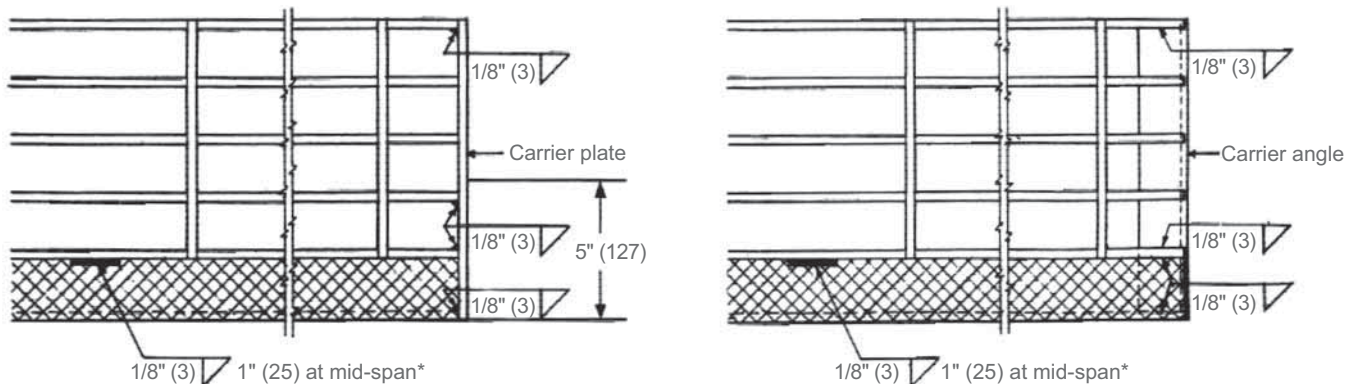

When carrier plates are used, the bearing bars and the nosing in the front five inches shall be welded to the carrier plate as shown.

On treads over 9-3/4" (248) wide, weld end of center bar also.

*Treads spanning 4' (1.2 m) or more shall have two welds, located at the third points.