

# CUSTOM FABRICATION

All types of fabrication typically associated with the grating industry are performed by experienced and expert craftsmen at Ohio Gratings. Services available include straight and circular cutting and banding, fabrication of radially cut grating panels, toe plate attachment, grating with checker plate, heavy duty grating with cross bars top and bottom, serrated heavy duty bearing bars and cross bars, egg-crate construction, vault grating, grating with hinges and locks, and heavy duty grating with spacer bars to form an extremely close mesh (see Wheels n' Heels® Heavy Duty Steel Grating).

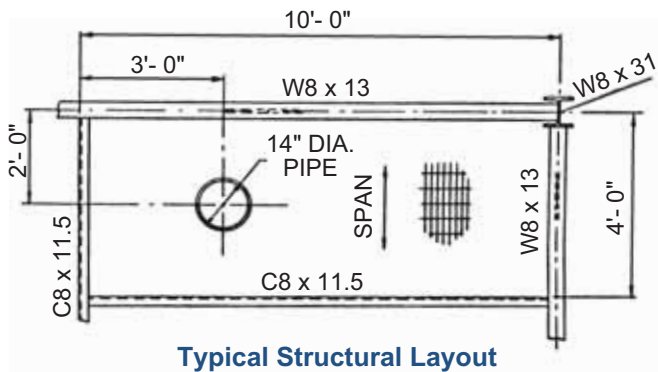

**Typical Structural Layout**

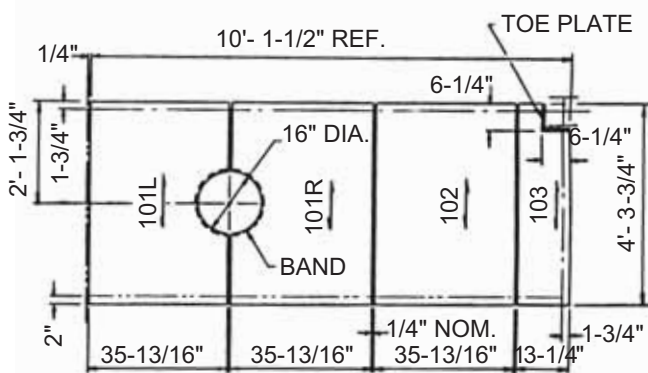

**Typical Panel Layout**

*Shown above is an example of a customer supplied structural drawing (top sketch) and the corresponding grating layout drawing as furnished by Ohio Gratings (bottom sketch).*

## Drawings & Templates

The majority of fabrication performed by Ohio Gratings is done in accordance with grating drawings prepared by the Engineering Department. These grating erection drawings are generally produced from the structural drawings, or grating outline drawings, as supplied by the customer.

Each grating panel is tagged with a mark number which corresponds to a mark number on the drawing. This marking system allows grating panels to be identified during the fabrication process, and, when used in conjunction with the grating drawing, facilitates the correct placement of grating panels during erection.

While some grating companies work from floor layouts, Ohio Gratings has chosen to employ personnel thoroughly versed in the trigonometry of grating design, and shop employees who are experts at blueprint reading. This combination has been found to be the most efficient approach to drawing preparation, customer drawing approval, and shop fabrication.

Occasionally, extremely intricate grating areas require that fabrication be accomplished from a template used to supplement the grating drawing. Templates supplied by the customer are usually made from cardboard or plastic. In addition to grating configuration, templates must indicate top and bottom sides, and whether or not they represent the size of the opening or the size of the grating. Grating can be fabricated from templates for a nominal charge, over and above the standard fabrication charge.

Please contact the factory regarding the electronic transfer of drawings via the Internet.



## FIBERGLASS FABRICATION

Ohio Gratings stocks and fabricates most major types of fiberglass grating. Molded fiberglass, both square mesh and rectangular mesh, as well as pultruded grating is available in panel form, or cut-to-length and fabricated per customer specifications. Ohio Gratings also has the ability to supply FRP platforms, ladders and handrail. For more information regarding OGI's FRP fabrication capabilities, please contact the factory.

# CUSTOM FABRICATION

## Grating/Plate Combinations

For those flooring areas requiring the solid surface of plate, and the structural strength and removability of grating, assemblies combining checkered or smooth plate with aluminum, light duty steel, or heavy duty steel can be furnished. Unless otherwise specified, 3/16" welds, one inch long on 12" centers in each direction are used to join grating and plate. Due to the rolled in stresses inherent in plate, and the subsequent stress release and warping which can accompany galvanizing, the following limitations apply to steel grating/checker plate assemblies:

1. Light Duty Steel Grating and Plate combinations will be furnished in the mill finished or painted black conditions only. Deviation from this policy will be at customer risk, i.e., flatness tolerances will not be guaranteed for galvanized material.
2. In addition to the painted or mill finished condition, Heavy Duty Grating/Plate assemblies having bearing bars 2" x 3/8" or larger can be provided with a galvanized finish.
3. Steel Grating/Plate combinations will be installed with the plate on the BOTTOM of the grating. When installed with the plate facing up, the cross bars will be on the bottom of the grating. This will apply to steel only (not aluminum).
4. Galvanized Steel Grating/Plate will be fabricated with 1/2" diameter handling/drain hole in one corner of the plate.

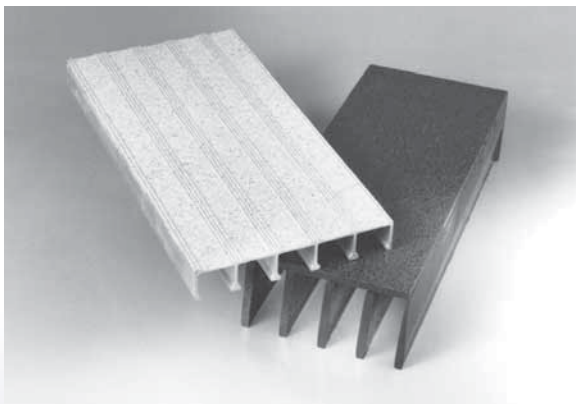

Shown above is a steel grating/solid plate assembly coated with a slip resistant, anti-skid surface. For applications requiring the light weight or corrosion resistance of an aluminum grating / checkerplate combination, unpunched plank (shown above with a slip resistant surface) offers an economical alternative.

## Serrated Rectangular Bearing Bars & Cross Bars

In order to achieve maximum skid resistance for wheel traffic, Ohio Gratings manufactures heavy duty welded steel grating with serrated rectangular bearing bars and cross bars. The rectangular cross bar design is especially suited to this application, providing a skid free surface, while at the same time offering lateral stability which is superior to the round cross rod design most common to the industry. Serrated bearing bars range from 1/4" thru 1/2" thick, while serrated cross bars are available in 1/4" and 3/8" thickness.

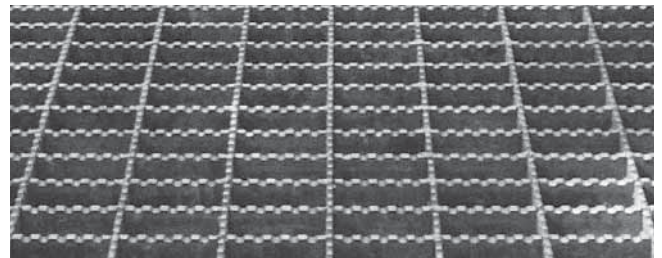

## Egg-Crate Construction

Occasionally requirements call for the cross bars to be larger than standard, or in some cases, equal in size to the bearing bars. This condition may necessitate the notching of both the bearing bar and the cross bar resulting in a type of construction known as "egg-crate". Unless otherwise specified, each internal intersection is welded at two of the four corners, while the outside intersection is welded at one of the two corners. Depth of weld can vary depending upon the depth of the grating and the opening between bars. In general, egg-crate construction is limited to bars from 2" to 6" in depth and ranging from 1/4" up to 1" in thickness, with a minimum clear opening ranging from 2" to 4", depending upon bar size. The maximum panel size is typically 50 - 60 SF per piece.

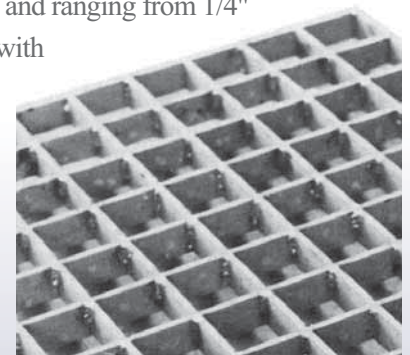

# CUSTOM FABRICATION

## Hinges, Locks & Lift Handles



Since grating is typically used to provide multiple level flooring, quite often, grating hatches are needed to facilitate access from one level to another.

Ohio Gratings has years

of experience in fabricating grating panels with hinges and lift handles, and with locking devices for security purposes. Numerous standard details have been developed, and are on file for customer use. Since these details are standard, they represent the most cost effective methods of fabrication, both from a labor, and from a material availability point of view.

## Cross Bars Top & Bottom

For those areas requiring added resistance to lateral forces, Ohio Gratings manufactures heavy duty welded steel grating with cross bars on the bottom, in addition to the standard cross bars which are located on the top. Bottom cross bars can be provided in rectangular or round design, and can be positioned as close together as 2" on center. Bottom cross bars are especially helpful in resisting the lateral impact of accelerating and decelerating wheel loads.

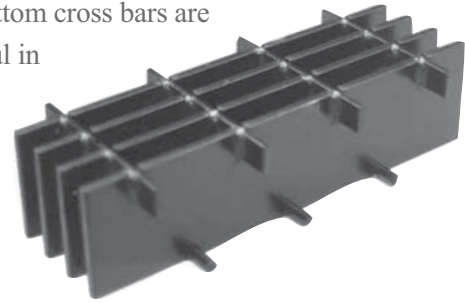

## Notching/Welding

Notching is somewhat common in the industry, however, not recommended under certain conditions. Please consult factory for recommendations.

\* Grating which is welded to an inverted angle or toe plate, and supported by the weld rather than by a bearing surface, is not recommended and should never be specified.

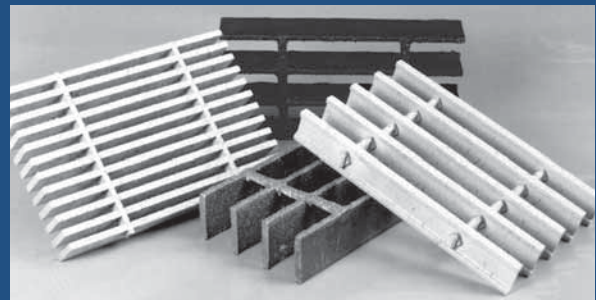
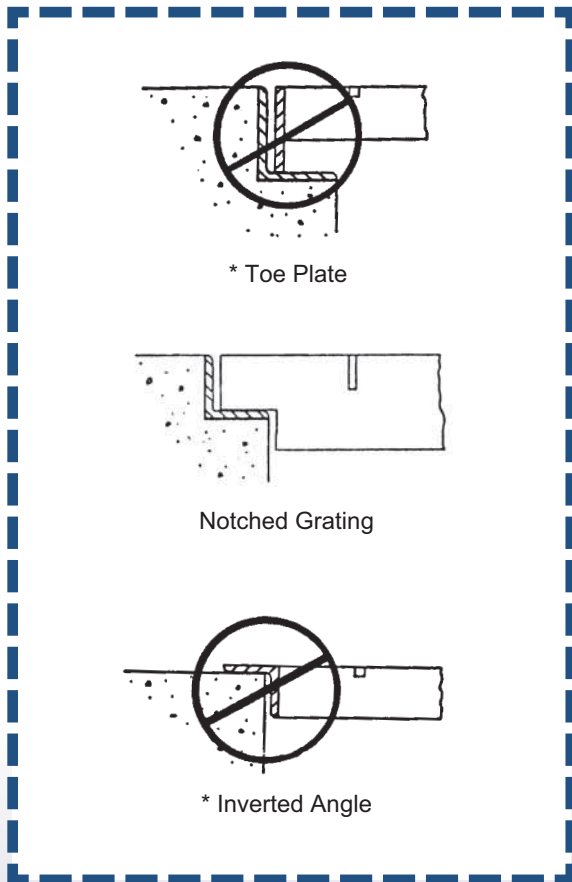

## Slip Resistant Surface

All Ohio Gratings' products are available with a slip resistant, metallic coating for maximum traction. This coating may be in the form of the plasma stream deposition of aluminum-on-aluminum or steel-on-steel, or may be in the form of a CNC laser deposition process. For the most suitable coating for your application, please contact the factory.