

# STANDARD INSTALLATION CLEARANCES

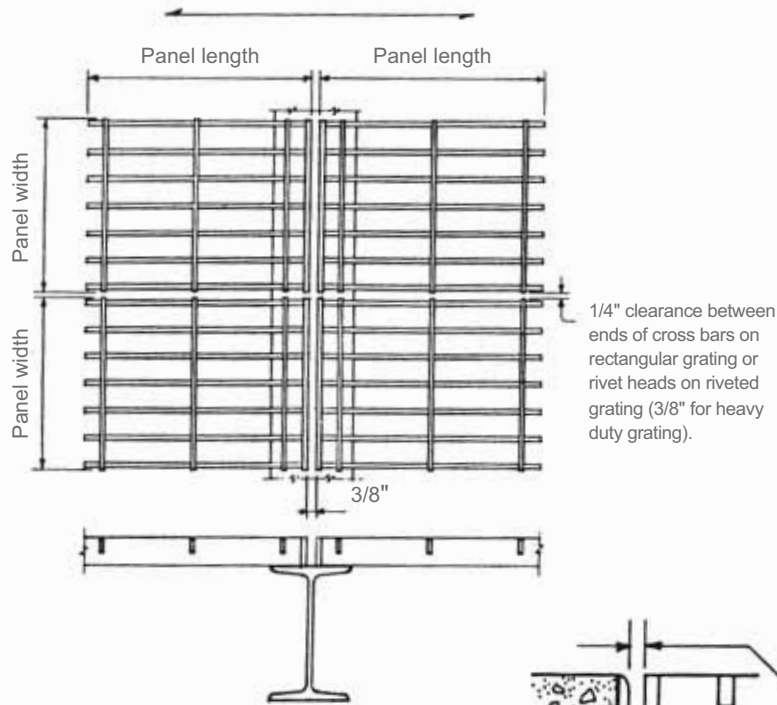

Banding may have less depth than bearing bars for trench grating to allow drainage. Full depth banding will be provided unless otherwise specified.

Clearances shown are recommended, but may vary in accordance with dimensional tolerances.

Heavy duty grating should be designed to have structural support under each bearing bar at cutouts.

As shown in the drawing below, all rectangular cutouts are made to the next bearing bar beyond the penetration with a clearance not to exceed bearing bar spacing.

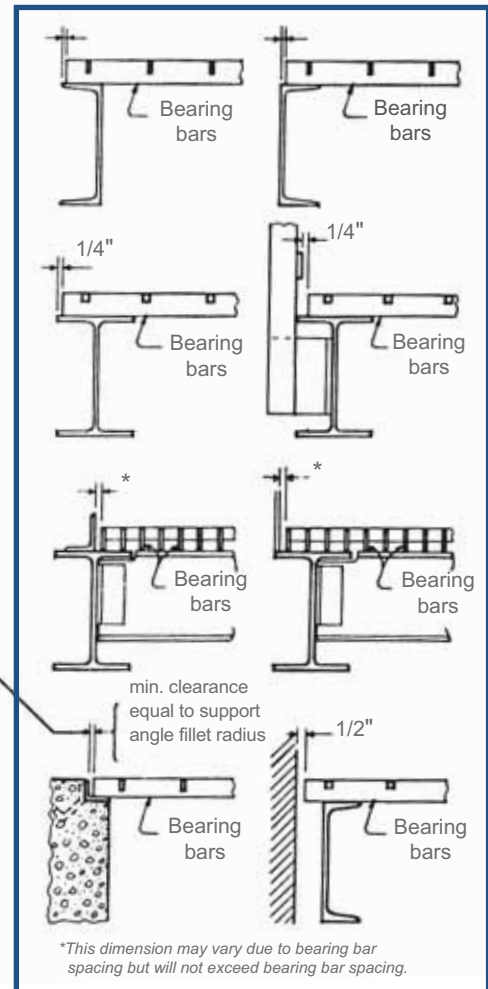
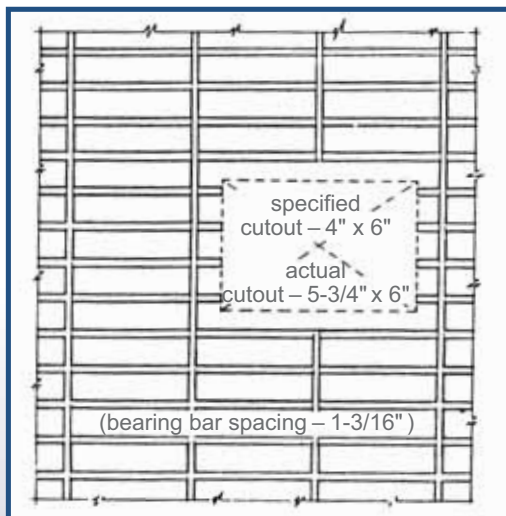

Cutouts for circular obstructions are recommended to be at least 2" larger in diameter than the obstruction. It is further recommended that cutouts for all piping 4" or less be made in the field.

## General Recommendations for Grating Installation

- Gratings must be installed with cross bars on top side.
- Notching of bearing bars at supports to maintain proper elevation is generally not recommended. If notching is required for installation, manufacturer should be consulted.
- Metal should always be used for all grating supports.
- A minimum of 1" bearing shall be provided for Aluminum and Light Duty Steel Grating. For Heavy Duty Steel Grating, 1" minimum bearing shall be provided for bearing bar depths up to 2-1/4", and 2" minimum bearing shall be provided for depths of 2-1/2" and over. This bearing surface does not include the support angle fillet radius noted above.